



▶ **BLDC Driver**

9522

- Phase current ... up to 20 A
- BUS interfaces... RS232, RS485, CAN
- Speed and position regulations
- PC user interface
- Sensorless solution

Thanks to a DSP processor, this user-friendly driver offers a high level of flexibility.

The 9522 Driver drives Brushless DC (BLDC) motors in sinusoidal power commutation. This operation mode ensures high torque stability and reduces motor noise significantly. The rotor position is defined with position feedback from motor integrating Hall sensors or additional rotary encoder. "2 phase ON" mode is used for sensorless commutation.

Motor dynamic performances can be optimized by setting the P and I parameters through the communication interface. Whether it is in speed or in position regulation, the calculation algorithm has to be adapted to the application.

RS232, RS485 or CAN protocols are available. A simple but complete PC interface is provided with the 9522 driver for setting adjustments.

PWM signal or analog voltage are used to regulate speed and/or position. Motor direction is set through a digital input. For test purpose a definable cycle can be programmed with the PC interface.

▶ **Main features**

- Supply voltage 12 V to 48 V
 - Phase current up to 20 A peak
 - 2 phases ON or 3 phases sinus
 - Speed and position regulations
 - Configuration through communication bus
 - PC user interface
- **Inputs / Outputs**
 - PWM input
 - Direction input (CW / CCW)
 - 0-10 V analog input
 - 0-10 V feedback output
 - Digital inputs

▶ **Technical data**

Supply Voltage [V]	Nominal phase current [A]	Peak current [A]	Max operating temperature [°C]	Storage temperature [°C]	Motor speed [rpm]	Dimension [mm]	Weight [g]
12 to 48	10	Up to 20	85	-40 ... +125	Up to 10'000	100 x 102 x 33	230

▶ Mechanical dimensions

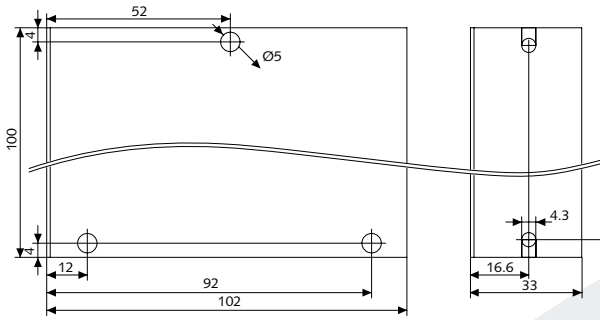

▶ Connection

• Driver connection

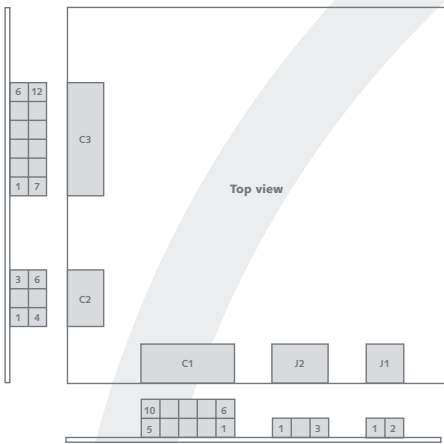

• Connector J1

1	Power supply
2	Ground

• Connector J2

1	Motor Phase A output (U1*)
2	Motor Phase B output (U2*)
3	Motor phase C output (U3*)

• Connector C1

Hall Input 1 (S1*)	1	6	Hall Input 2 (S2*)
Hall Input 3 (S3*)	2	7	Hall Vcc
Hall GND	3	8	Encoder GND
Encoder Vcc	4	9	Encoder Index
Encoder Input B	5	10	Encoder Input A

• Connector C2

CAN Low	1	4	CAN High
GND	2	5	GND
UART TX	3	6	UART RX

• Connector C3

PWM Input	1	7	Dig input enable
Dig input 1	2	8	Dig input direction
Dig input 2	3	9	Digital GND
D/A Output A	4	10	D/A Output B
D/A GND	5	11	A/D GND
A/D input	6	12	A/D VRef

* 5455 Sonceboz motor terminology

▶ Electrical interface

Inputs

- Analog (speed or position)	0-5 V (Max 10 V)
- Digital (direction, circuit enable, D1, D2)	5 V (Max 24 V)
- PWM	5 V (Max 24 V)

Outputs

- Analog (feedback 1, feedback 2)	0-10 V
- Optical encoder power supply	5 V
- Hall sensor power supply	12 V

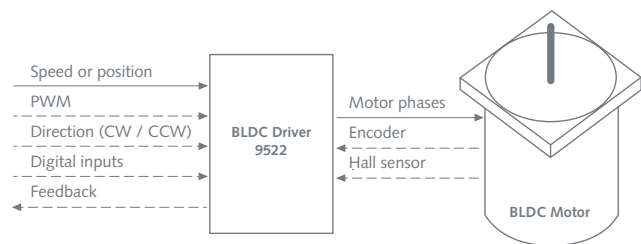

Special requirements upon customer specifications. Right to change reserved without notices.

< 1.0 >