

► Torque motor

4276

- Working angle 75°
- Positioning time < 100 ms
- Weight 330 g
- Peak torque @ 13.5V .. 560 mNm

This motor is a contactless direct drive device and exhibits both high torque and dynamics.

► Technical data

Resistance [Ω]	Inductance [mH]	Torque constant [mNm/A]	Motor constant [mNm/√W]	Detent torque [mNm]	Sensor signal
2.1	14	100	69	38	Programmable: - Analog: 0.5 to 4.5 V - Digital: PWM / SENT

► Dimensions

Drawing not to scale. All dimensions in mm.

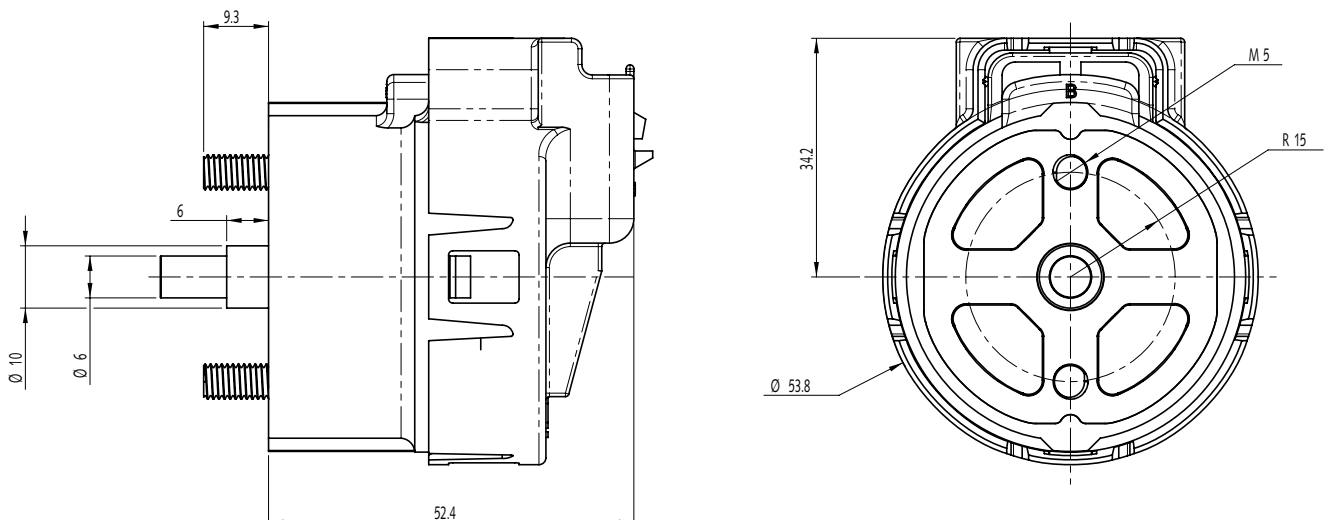

► Dynamic characteristics

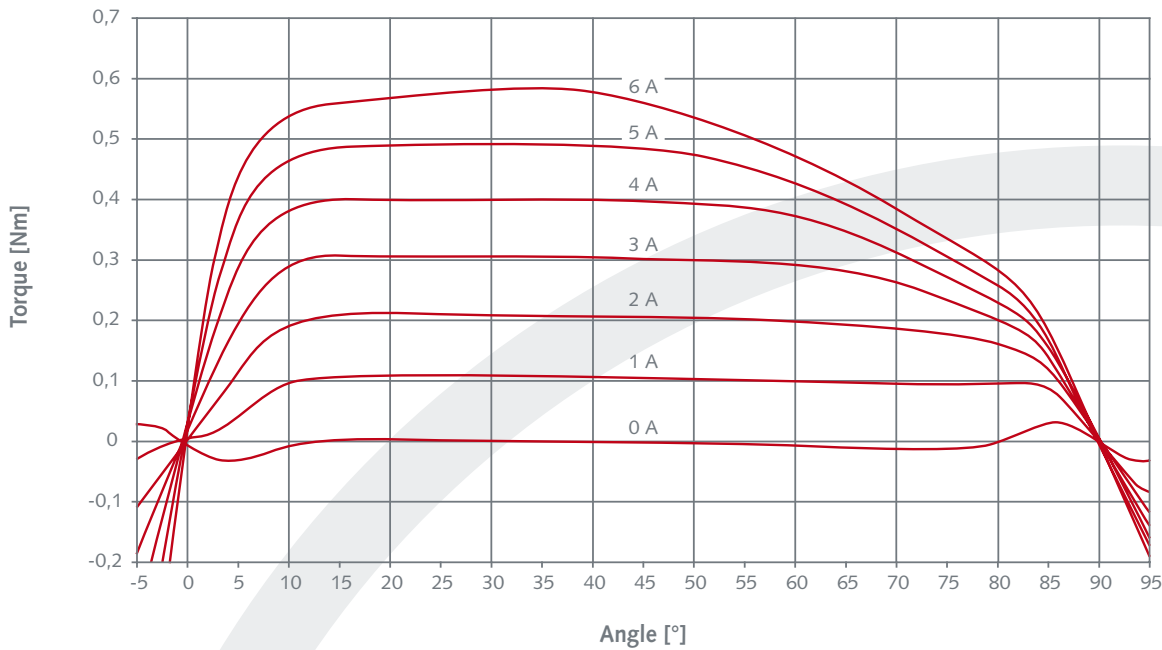

► Main Features

- Compact, robust, contactless
- Single phase DC operation (2 leads)
- Nominal torque proportional to current, bi-directional and constant over the stroke (75°)
- High peak torque
- Programmable contactless position sensor
- Integration of return spring possible
- Integration of drive electronics possible

► Operating conditions

Qualified for on-engine applications:

- Ambient temperature: -40 ... +150° C
- Vibrations: 40 g

Special requirements upon customer specifications. Right to change reserved.

< 1.0 >

SONCEBOZ SA
 2605 Sonceboz - Switzerland
 Tel. +41(0) 32 488 11 11
 Fax +41(0) 32 488 11 00
 E-mail : info@sonceboz.com
 Internet : www.sonceboz.com

